

ISO9001:2008

REGISTERED



Alternate Energy Systems, Inc.

A Company devoted to Your Energy Needs

LPG-Vapor / Air Mixing Systems

Patented Piston Operated Mixers

- **Compact Design**
- **Low Maintenance**
- **Superior Reliability**
- **Small Footprint**
- **High Capacity**
- **National and International Patents**
- **For Low Pressure or High Pressure Applications.**
- **Rosemount Transmitters, Allen-Bradley PLC.**
- **For Standby Systems or Peak Shaving Applications.**
- **Capacities from 20 MM BTU/h to over 400 MM BTU/h.**
- **Option: Complete System Integration with Vaporizers.**
- **Option: Automatic Control of Wobbe #, O₂ content, Calorific Value, or Specific Gravity.**
- **Option: Flow Controller for Peak Shaving.**
- **Option: Remote Control via Ethernet.**
- **Option: Installation in Mobile Buildings.**

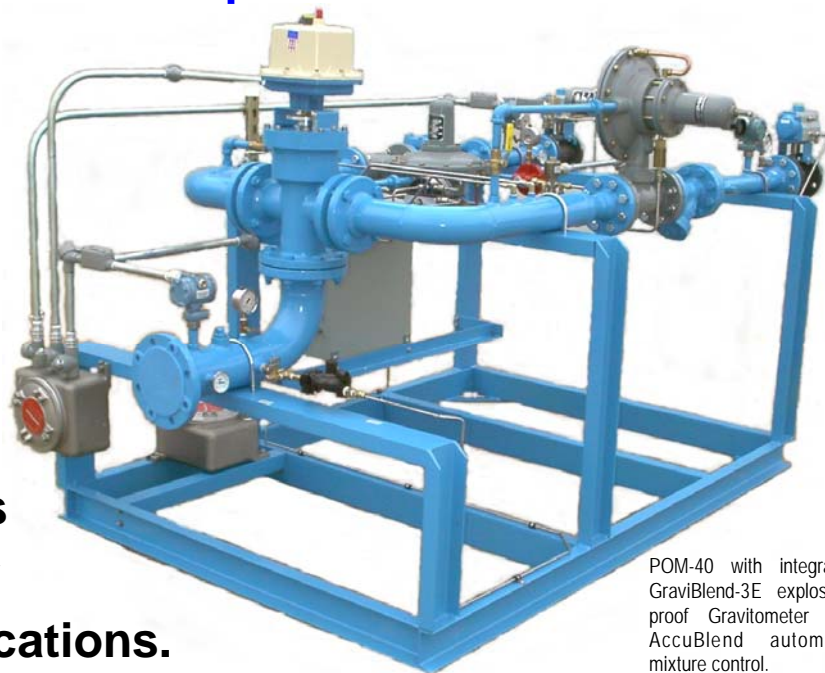

POM-40 with integrated GraviBlend-3E explosion-proof Gravimeter and AccuBlend automatic mixture control.

What are LPG-Vapor / Air Mixers ?

LPG vapor from a vaporizer or a storage tank is not directly compatible with natural gas and can therefore not be used for standby or backup purposes. LPG vapor/air mixers inject air into the LPG vapor stream and thereby produce a gas mixture that is directly compatible and interchangeable with natural gas. This allows users to switch back and forth between natural gas supplied by their utility company and their own, LPG based backup system, without having to change the setup of their any of their process or heating equipment, such as burners, boilers, heater, dryers, kilns, drum ovens, etc.

The most common vapor/air mixers are based on venturi tube mixing devices. For larger system capacities, or for applications with higher system pressures, AES uses our patented Piston Operated Mixer. This concept also allows for very comfortable and reliable automatic controls of the mixed gas properties.

Standard Features and Options

Standard Features:

- Nominal capacities from 20 MMBTU/h @ 10 psi to over 400 MMBTU/h @ 40-100 psi.
- Flanged Mixed Gas Outlet.
- Flanged Vapor Inlet and Compressed Air Inlet.
- Rosemount Transmitters for Vapor Pressure, Compressed Air Pressure, Mixed Gas Pressure, Vapor/Air Differential Pressure.
- Siemens or Allen-Bradley Programmable Logic Controller (PLC) for all safety and process control functions.
- Full-graphic color LCD display with touch-screen operator interface, for system start/stop and parameter display. Trend Graphics with up to seven days local data storage.
- Pneumatic safety actuators (fail-safe closed) on vapor and air inlet valves.
- Can be installed outdoor or indoor.
- UL listed Solenoid Valve in regulator loading line.
- Blenders are FM and CSA approved, are suitable for IRI installations, and are available with European CE Mark.
- Factory Primed, Painted, and Tested – ready for installation.

Options:

- Custom Control Panels.
- Custom System Integration.
- Complete Packages with Vaporizers.
- Flow Meters and Gravimeters/Calorimeters.
- Automatic Gas Properties Controller (AccuBlend™) for correction of Calorific Value, Wobbe Number, Specific Gravity.
- Temperature Transmitters for Vapor Supply, Compressed Air Supply, Mixed Gas Outlet.
- Remote Monitoring and Control via Ethernet/Internet without special software through built-in web servers.



Typical Touch Screen Operator Interface. Siemens S7-1200 PLC with Ethernet Interface and DSL Router.

LP/Air Applications

AES Piston Operated Mixers have received national and international patents. They have been manufactured since then with a number of improvements of their control components, but without any changes to the main design concept. The blenders have been approved by Factory Mutual (FM Global) and CSA. Blenders with European CE Mark comply with all applicable EU Directives (ATEX, PED, etc.).

Installations around the world include Peak Shaving Plants for Gas Utilities; Standby Plants for large industrial users; Backup Systems for government and defense installations; Primary Fuel Source for areas without natural gas supply or for areas preparing for connection to natural gas; Power Plants; in Glass, Ceramics and Brick Manufacturing; Chemical Plants; Metal Processing; Food Processing; etc.

AES Piston Operated Mixers can be used with AES LPG vaporizers, or with existing vaporizers from other manufacturers. Using them with AES vaporizers allows complete integration with sophisticated, computerized system controls, including remote monitoring and operation.

Other Applications

In addition to the LP/Air blending applications, POM blenders have also proven to be ideal for other gas/gas blending applications. These applications include NatGas stabilization for critical production lines; production of "City Gas" from NatGas and Air or LPG-vapor and air; Coke Oven Gas replacement with NatGas and Air, LPG-vapor and air, or NatGas and Nitrogen; backup for Landfill Gas fired turbines with NatGas/Air or LPG-vapor/Air; backup for Digester Gas fired engines; conditioning of Digester Gas to improve combustion and reduce emissions; and a number of other gas/gas blending applications.

In general, POM blenders can be used for any gas/gas blending application where the gasses are compatible with the materials of the blender. Standard material is Carbon Steel, but the design of the POM also allows it to be manufactured from Stainless Steel or "exotic" materials.

Contact Alternate Energy Systems if you have an application that is not listed above. We will be able to respond within one to two business days with a system design concept and a price and delivery estimate.

How do Alternate Energy Systems' POM LPG-Vapor / Air Mixers work ?

Standard high capacity / high pressure LPG vapor / air mixers used to be very complicated pieces of machinery, difficult to set up, and requiring a very high level of maintenance. With the advent of the POM, "Piston Operated Mixer", these installer and operator "nightmares" are a thing of the past. The impressive simplicity of the POM guarantees the ultimate in accuracy, reliability and flexibility, and allows the POM to be manufactured in virtually any capacity and of any material compatible with the gasses that are being blended. By using a piston, there are no design pressure or temperature restrictions commonly found with diaphragms, which have high-temperature restrictions or may stiffen and crack in cold temperatures.

Compared to systems with proportional mixing valves, which typically use differential pressure feedback, POM systems impress with their simple installation, setup, operation and maintenance, their unsurpassed operational reliability, their quick response to load changes, and their turn-down ratio of 50:1 or better.

Compared to blending systems that rely on the presence and accuracy of Vortex (or other types of) flow meters to pre-set the blending ratio ("feed-forward" or "forward control"), and then have to wait for a signal from a gas analyzer (usually a Calorimeter) to make adjustments to the blending ratio until the actual gas properties match the desired values (feed-back), POM blenders are much faster to respond to load changes (flow changes).

While the flow meter based blenders cannot operate accurately without the presence of a gas analyzer, POM blenders will maintain their blending ratio regardless of the flow demand. This has been proven time-and-time again in demanding applications. A typical example for this is the fuel supply to float glass plants, where the periodic "reversals" (100% flow for 20 minutes; 100% to 0% in 10 seconds; no-flow for several seconds; 0% to 100% in 5-10 seconds) usually upset flow meter based blenders to the point that some users have decided to use them for "Asset Protection" only, but not for "Profit Protection" (keep the furnace warm, but don't produce glass, because the gas properties are not good enough). POM blenders, on the other hand, have no problem maintaining the blending ratio even under these conditions, and have therefore become a quasi-standard for the glass industry.

Once set, the POM will blend two gasses at a constant ratio: the result is an LPG / air mixture which is compatible with natural gas, regardless of the downstream demand. The POM system is a "pushthru" system. This means that it is not necessary to reduce the compressed air or the LPG vapor to zero pressure during the mixing process, before compressing both air and gas to the desired pressure. The POM system utilizes the existing pressure in the LPG to satisfy most industrial and utility peak shaving applications.

HOW IT WORKS – The dominant gas (i.e. LPG) enters the mixer at Inlet Port "A". The blend gas (i.e. compressed air) enters at Inlet Port "B". Both gasses exit together at Exit Port "C". A small connecting bore connects Inlet Port "A" with Chamber "D" and, another bore connects Chamber "E" (through the piston) with Exit Port "C".

When turned off, or during no-flow periods, the piston rests in the closed position. Upon demand for gas, pressure at Exit Port "C" drops slightly. This change in pressure is passed through the piston to Chamber "E". The pressure at Inlet Port "A" (dominant gas) is greater and, since this area connects to Chamber "D", the piston will rise or descend with demand changes or pressure drops at Exit Port "C". When the flow rate is constant, the piston will "float", partially opening the inlet gates A and B. This results in a very accurate positioning of the piston, accurately metering the flow of gas, regardless of the downstream demand.

RATIO ADJUSTMENT – A segment "G", cut out of the piston, matches the edge of the cutouts in Port "A-B". The piston is positioned between a sliding, pinned guide and the top of the piston. A knurled knob, attached to the stem of the guide, easily allows adjustment to be made externally by rotating the guide (and with it the piston), to restrict either Inlet Port, thereby controlling the ratio of gas and air. The piston is designed with a series of grooves, called a "labyrinth", which generates circular "O" rings or vortices which prevents the gasses from transferring between the top and bottom chambers. This design eliminates the need for a diaphragm or a mechanical seal such as a piston ring. It also allows the POM to be equipped with an actuator/positioner for automatic correction of the properties of the mixed gas, i.e. Calorific Value, Wobbe Index Number, O₂ content, Specific Gravity, etc.

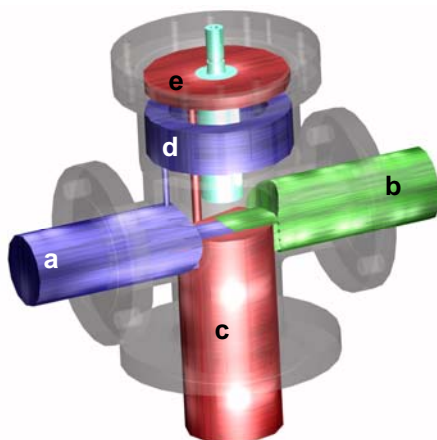

Gas Flow through POM Valve

Legend:

- A Dominant Gas Inlet (LPG)
- B Compressed Air Inlet
- C Mixed Gas Outlet
- D Dominant Gas Loading Chamber
- E Mixed Gas Flow Sensing Chamber
- F Piston
- G Piston Cutout for Ratio Adjustment

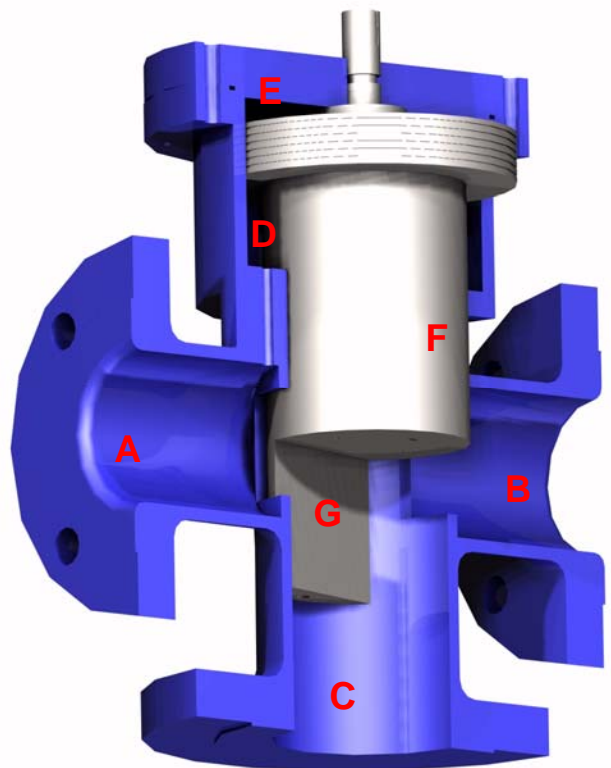

Specifications

SPECIFICATIONS ³		POM - 30	POM - 40	POM - 60	POM - 80 and higher
Type		Equal Pressure Blending System / Patented Piston Operated Mixer. US-Patents, International Patents			
Max. Capacity ¹ at 10 psi / 0.7 bar NatGas Replacement ⁴	MMBTU/h Nm ³ /h	20 560	80 2260	140 4000	consult factory
Max. Capacity ¹ at 30 psi / 2.1 bar NatGas Replacement ⁴	MMBTU/h Nm ³ /h	80 2260	200 5660	320 9060	consult factory
Max. Capacity ¹ at 50 psi / 3.5 bar NatGas Replacement ⁴	MMBTU/h Nm ³ /h	120 3400	280 7930	400+ 11330+	consult factory
Max. Capacity ¹ at 70 psi / 4.9 bar NatGas Replacement ⁴	MMBTU/h Nm ³ /h	180 5100	400+ 11330+	400+ 11330+	consult factory
Max. Capacity ¹ at 100 psi / 6.9 bar NatGas Replacement ⁴	MMBTU/h Nm ³ /h	240 6800	400+ 11330+	400+ 11330+	consult factory
Design Temperature	°F °C	180 82	180 82	180 82	consult factory
Manufactured Construction		Conforms to ASME Boiler & Pressure Vessel Code and latest Edition of NFPA # 58			
Approvals		Factory Mutual (FM) and CSA; suitable for Industrial Risk Insurers (IRI) installations; Control Panel can be UL 508a stamped; CE Mark (ATEX; PED; etc.) for export units to Europe;			
Standard Safety Features		All system status signals are constantly monitored through a Programmable Logic Controller (PLC; Siemens or Allen-Bradley). Process values and any alarm conditions are communicated to, and displayed at, the color LCD display with touch screen operator interface in plain English; other languages available.			
High Mixed Gas Pressure		Rosemount electronic pressure transmitter in mixed gas outlet. Setpoint adjustable through Operator Interface.			
Low Mixed Gas Pressure		Rosemount electronic pressure transmitter in mixed gas outlet. Setpoint adjustable through Operator Interface.			
High LPG Vapor Pressure		Rosemount electronic pressure transmitter in vapor supply line. Setpoint adjustable through Operator Interface.			
Low LPG Vapor Pressure		Rosemount electronic pressure transmitter in vapor supply line. Setpoint adjustable through Operator Interface.			
High Air Supply Pressure		Rosemount electronic pressure transmitter in compressed air supply line. Setpoint adjustable through Operator Interface.			
Low Air Supply Pressure		Rosemount electronic pressure transmitter in compressed air supply line. Setpoint adjustable through Operator Interface.			
Excess Differential Pressure		Rosemount electronic differential pressure transmitter between downstream vapor and air lines. Setpoint adjustable through Operator Interface.			
Local Indicators		Thermometers and liquid filled pressure gauges for vapor supply, compressed air supply and mixed gas outlet. Vapor/air differential gauge.			
Safety Valves in Vapor and Air Inlet		Air-actuated ball valves close on high-pressure alarms. Fail-safe design with spring- return closes valves on power failure or high-pressure alarm.			
Vapor Supply Connection	domestic Export	2" 300# RF ANSI Flange DN50 PN25 DIN Flange	2" 300# RF ANSI Flange DN50 PN25 DIN Flange	2" 300# RF ANSI Flange DN50 PN25 DIN Flange	consult factory
Minimum Vapor Supply Pressure		15 psi (1 bar) above system sendout pressure (preferred). 5 psi (0.35 bar) available; contact AES for details.			
Compressed Air Supply Connection	domestic Export	2" 150# RF ANSI Flange DN50 PN16 DIN Flange	2" 150# RF ANSI Flange DN50 PN16 DIN Flange	2" 150# RF ANSI Flange DN50 PN16 DIN Flange	consult factory
Minimum Compressed Air Supply Pressure		15 psi (1 bar) above system sendout pressure (preferred). 5 psi (0.35 bar) available; contact AES for details.			
Mixed Gas Outlet Connection	domestic Export	3" 150# RF ANSI Flange DN80 PN16 DIN Flange	4" 150# RF ANSI Flange DN100 PN16 DIN Flange	6" 150# RF ANSI Flange DN100 PN16 DIN Flange	consult factory
Electrical Requirements	domestic Export	AC 110 V 60 Hz 3 A, Single Phase AC 220 V 50 Hz 3 A, Single Phase			
Dimensions ² (W x L x H)	inch mm	54 x 92 x 53 1372 x 2337 x 1346	54 x 96 x 57 1372 x 2438 x 1448	54 x 103 x 64 1372 x 2616 x 1626	consult factory
Weight ²	lbs kg	1000 455	1050 480	1200 550	consult factory

¹ Nominal Capacity for Propane with 1450 BTU/cuft (12900 kcal/m³) Propane/Air Mix @ 25 to 250 psig. Capacity for other LPG mixtures may vary.

² Dimensions and weights are approximate. ³ Specifications subject to change without notice.

⁴ NatGas Replacement = equipment consumption of standard NatGas with 1000 BTU/cuft (8900 kcal/m³).

POM Selection Chart

To find the right POM for your application, select the required nominal system capacity from the first column of the chart. Move to the right until you are below the system design pressure (delivered mixed gas pressure). The top row of the cell indicates the POM model number. The bottom row of the cell indicates the POM configuration (regulator type / orifice size).

Nominal Capacity in MMBTU per hour (top row) and Nm³/h (bottom row) is given for Propane/air mixture with 1450 BTU/cuft at delivered mixed gas pressures of 10 psig to 100 psig. Capacity for other LPG/air mixtures and/or pressures may vary. Nominal Capacity is based on vapor and compressed air inlet pressures of 15 psi (1 bar) above sendout pressure, and a pressure drop of less than 10% across the mixing valve at maximum flow. The number for Nm³/h (bottom row) refers to "NatGas Replacement", which is defined as "equipment consumption of standard NatGas with 1000 BTU/cuft (8900 kcal/m³)".

Other flow rate/pressure combinations are available. Please contact Alternate Energy Systems for your specific needs.

	10 psi 0.7 bar	20 psi 1.4 bar	30 psi 2.1 bar	40 psi 2.8 bar	50 psi 3.5 bar	60 psi 4.2 bar	70 psi 4.9 bar	80 psi 5.6 bar	90 psi 6.3 bar	100 psi 7 bar
20 MM 560 m ³	POM-30 9978	POM-30 9978	POM-30 9978	POM-30 9978	POM-30 9978	POM-30 9978	POM-30 9978	POM-30 9978	POM-30 9978	POM-30 9978
40 MM 1130 m ³	POM-40 9978	POM-30 9978	POM-30 9978	POM-30 9978	POM-30 9978	POM-30 9978	POM-30 9978	POM-30 9978	POM-30 9978	POM-30 9978
60 MM 1700 m ³	POM-40 9978	POM-30 9978	POM-30 9978	POM-30 9978	POM-30 9978	POM-30 9978	POM-30 9978	POM-30 9978	POM-30 9978	POM-30 9978
80 MM 2260 m ³	POM-40 9978	POM-40 9978	POM-30 9978	POM-30 9978	POM-30 9978	POM-30 9978	POM-30 9978	POM-30 9978	POM-30 9978	POM-30 99118
100 MM 2800 m ³	POM-60 9978	POM-40 9978	POM-40 9978	POM-30 9978	POM-30 9978	POM-30 9978	POM-30 9978	POM-30 9978	POM-30 99118	POM-30 99118
120 MM 3400 m ³	POM-60 99118	POM-40 99118	POM-40 99118	POM-40 99118	POM-30 99118	POM-30 99118	POM-30 99118	POM-30 99118	POM-30 99118	POM-30 99118
140 MM 4000 m ³	POM-60 99118	POM-60 99118	POM-40 99118	POM-40 99118	POM-40 99118	POM-30 9835100	POM-30 9835100	POM-30 9835100	POM-30 9835100	POM-30 9835100
160 MM 4530 m ³		POM-60 99118	POM-40 99118	POM-40 99118	POM-40 99118	POM-40 99118	POM-30 9835100	POM-30 9835100	POM-30 9835100	POM-30 9835100
180 MM 5100 m ³		POM-60 99118	POM-40 99118	POM-40 99118	POM-40 99118	POM-40 99118	POM-30 9835100	POM-30 9835100	POM-30 9835100	POM-30 9835100
200 MM 5660 m ³		POM-60 99118	POM-40 99118	POM-40 99118	POM-40 99118	POM-40 99118	POM-40 99118	POM-30 9835100	POM-30 9835100	POM-30 9835100
220 MM 6230 m ³		POM-60 98340	POM-60 98340	POM-40 9835100	POM-40 9835100	POM-40 9835100	POM-40 9835100	POM-40 9835100	POM-30 9835100	POM-30 9835100
240 MM 6800 m ³		POM-60 98340	POM-60 98340	POM-40 9835100	POM-40 9835100	POM-40 9835100	POM-40 9835100	POM-40 9835100	POM-40 9835100	POM-30 9835100
260 MM 7360 m ³			POM-60 98340	POM-60 9835100	POM-40 9835100	POM-40 9835100	POM-40 9835100	POM-40 9835100	POM-40 9835100	POM-40 9835100
280 MM 7930 m ³			POM-60 98340	POM-60 9835100	POM-40 9835100	POM-40 9835100	POM-40 9835100	POM-40 9835100	POM-40 9835100	POM-40 9835100
300 MM 8800 m ³			POM-60 98340	POM-60 9835100	POM-60 9835100	POM-40 9835100	POM-40 9835100	POM-40 9835100	POM-40 9835100	POM-40 9835100
320 MM 9060 m ³			POM-60 98340	POM-60 9835100	POM-60 9835100	POM-40 9835100	POM-40 9835100	POM-40 9835100	POM-40 9835100	POM-40 9835100
340 MM 9630 m ³				POM-60 9835100	POM-60 9835100	POM-40 9835100	POM-40 9835100	POM-40 9835100	POM-40 9835100	POM-40 9835100
360 MM 10200 m ³				POM-60 9835100	POM-60 9835100	POM-60 9835100	POM-40 9835100	POM-40 9835100	POM-40 9835100	POM-40 9835100
380 MM 10760 m ³				POM-60 9835100	POM-60 9835100	POM-60 9835100	POM-40 9835100	POM-40 9835100	POM-40 9835100	POM-40 9835100
400 MM 11330 m ³				POM-60 9835100	POM-60 9835100	POM-60 9835100	POM-40 9835100	POM-40 9835100	POM-40 9835100	POM-40 9835100

Drawings, Dimensions

Dimensions in inches				
Dimensions in mm				
	W _S	L _S	L _T	H
POM-30	54	72	92	53
POM-40	54	76	96	57
POM-60	54	84	103	64
	1372	1829	2337	1346
	1372	1930	2438	1448
	1372	2134	2616	1626

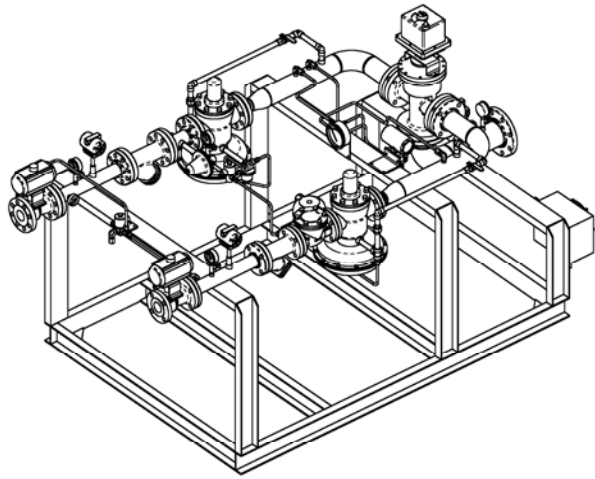

Safety Valves in Vapor Inlet and Air Inlet are pneumatically actuated and "fail-safe" through spring-return to "Closed" position in case of power failure or high-pressure alarm.

Standard regulator type on all POM models is Fisher 99 or similar. POM models for certain applications may be equipped with regulator type Fisher 1098-EGR or similar as shown in sample drawing.

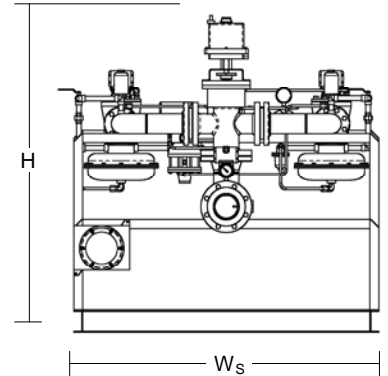
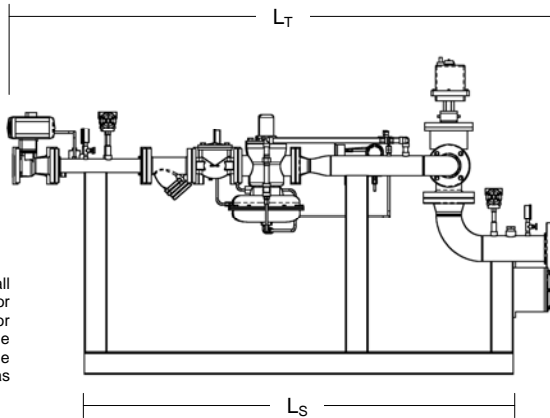

Typical System Configuration (P&I D)

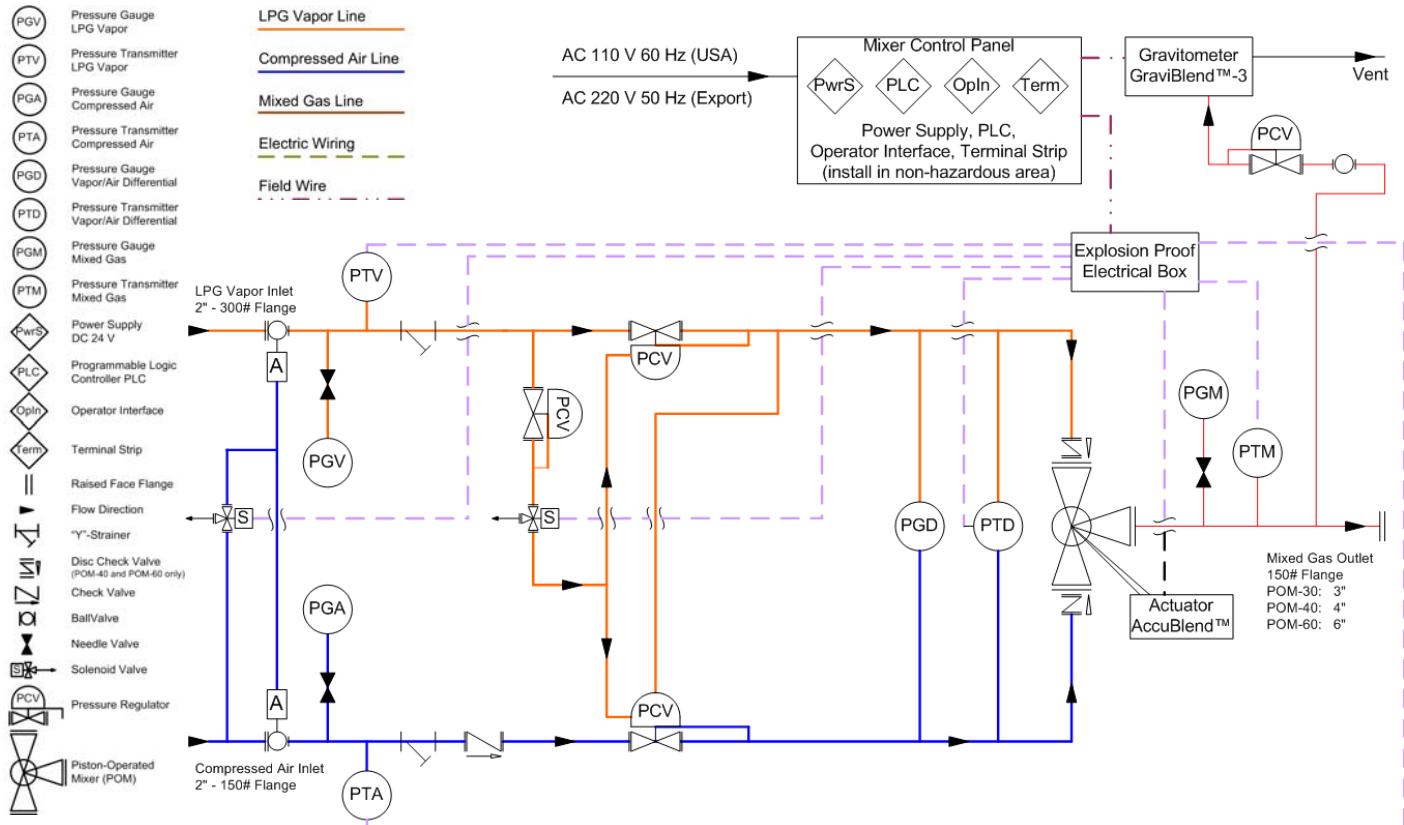

Options and Accessories

AccuBlend™ – Automatic Control of Gas Properties

All AES patented Piston Operated Mixers (POM-30 to POM-80) can be equipped with this option. It consists of an electric actuator, mounted on top of the POM valve, and a dedicated proportional controller. The controller receives the 4-20 mA signal from a gas analyzer, and compares this signal with a pre-set value, representing the correct mixture. If deviations are detected, the actuator changes the rotational position of the piston in the POM valve, thereby effectively correcting the mixture to meet customer requirements. When the AES GraviBlend®-3 is used, the function of the controller is integrated into the microprocessor-controls of the GraviBlend®-3.



GraviBlend®-3 – High-Speed, Real-Time Gravimeter

GraviBlend®-3 Gravimeters measure the Specific Gravity (SG) of the LPG/Air mixture. The resulting signal is an indicator for the quality of the produced gas. Maintaining a consistent SG value of the LPG/air mixture is important in applications where variations in the gas properties would change the heat output of a burner or furnace, and where this change would have a negative effect on the process.

If combined with the AccuBlend™ option, the signal from the Gravimeter is looped back to the positioner/actuator at the mixing valve, which then changes the gas/air ratio to correct any variations in the SG of the mixed gas.



PeakShaving Controller

All AES POM mixers can be equipped with PeakShaving Controllers. These are typically designed to meet the needs of a specific customer. However, they all have a number of features in common:

- Electronic Flow Control Valve, pneumatically actuated
- SNG Flow Transmitter (SNG = Synthetic Natural Gas)
- PANG Flow Transmitter (PANG = Propane-Air-Natural-Gas)
- Selectable Operating Modes
 - Inject SNG at fixed volumetric flow rate (SCFM - SCFH - Nm³/h - ...)
 - Inject SNG at fixed energy flow rate (MMBTU/h - MJ/h - kcal/h - ...)
 - Maintain NatGas/SNG Ratio
 - Manual Mode or Fully Automatic Mode
- System Protection
 - Limit flow to maximum vaporizer capacity
 - Limit flow to keep Specific Gravity of PANG below 0.9

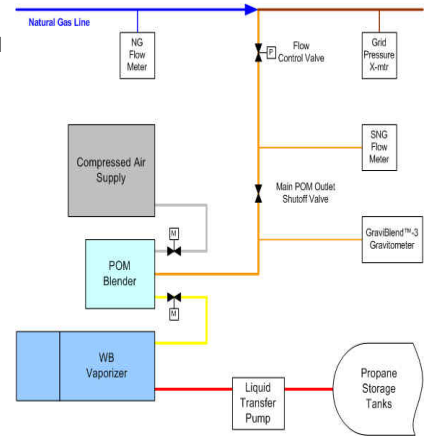

“Piggy-Back” or “On-Skid” Installation

In installations with limited space, the POM can be installed on the same skid with, or on top of, a standard AES water bath vaporizer.

This option includes the installation of the mixer control panel in the vaporizer control room, and wiring of all control components and transmitters to the panel.

Installation on top of the vaporizer is available for vaporizer models WB-1000 to WB-4500 and must be specified at the time of the order.

Installation on the same skid as the vaporizer is available for all vaporizer/blender combinations. POM blenders for on-skid installation are configured “vertical” for maximum space saving.

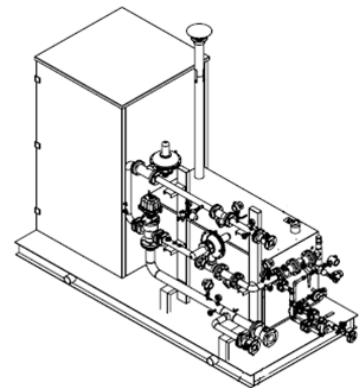

Separate Mixer Building

Customers in areas with extreme weather conditions often require LPG/Air mixing equipment to be installed in separate buildings. AES has developed a building concept that is based on modified 20ft or 40ft ISO shipping containers. This makes the structures easy to transport to the installation site, without the need for special-transport-permits. All mixing equipment is factory pre-installed and fully tested, considerably reducing the installation time. A typical building has the main mixer room, and a separate room for the system control panel. This room also provides heated/climate controlled, insulated space for operating personnel. Both building sizes offer room for two mixers. The 40ft building also has room to house air compressors with a combined capacity of up to 300 kW.

POM Blenders can also be installed together with the vaporizer and the compressed air supply in a single building, also based on modified 20ft or 40ft ISO shipping containers. Call AES to inquire about our i-Blend line, or download a brochure from the “Downloads” section on our web site.



Who is Alternate Energy Systems, Inc. ?

After working for other manufacturers of LPG vaporizers and LPG / air systems for several years, John E. Hallberg founded Alternate Energy Systems, Inc. in 1974 in Peachtree City, located just 20 minutes south-west of the Atlanta airport. He successfully set out to design and manufacture products which were superior to those of his competitors. As a result, AES became very quickly known as the innovative manufacturer of quality products. Soon, the customer list included a representative cross-section of the Fortune 500 companies in the U.S.



Through the years, AES has constantly added new products, and has further improved the design of existing products, keeping us ahead of the competition. Several designs, including those for LPG/Air mixing systems, were awarded national and international patents.

Today, AES is owned by Wolfgang Driftmeier. With his manufacturing background and his experience in sales and marketing, the company focus is clearly on "... offering the best product design, combined with quality workmanship, at a competitive price, to the full satisfaction of our customers, at all times ...".

AES is committed to serving customers in the U.S. through a network of sales specialists, technical support personnel, distributors and installers, and international customers in selected countries through qualified representatives.

Please visit our web site at www.altenergy.com for updated versions of all data sheets, price lists, application notes, a list of authorized distributors, and other documents that are only available online.

Other Products from Alternate Energy Systems, Inc.

Water Bath Vaporizers
Hot Water Vaporizers
Steam Vaporizers

Electric Vaporizers
Electric Water Bath Vaporizers

Venturi Type LPG / Air Mixers
Patented Piston Operated LPG / Air Mixers

Complete Vaporizer / Mixer Systems
Peak Shaving Plants
Gas Stabilization Systems

Accessories for LPG / Air Systems
LPG Pump Packages

Service
Maintenance
Trouble Shooting

Our Address

Alternate Energy Systems, Inc.
210 Prospect Park P.O. Box 2469
Peachtree City, GA 30269, USA

Phone 770-487-8596
Fax 770-631-4306
Toll Free 800-410-9161

E-Mail info@altenergy.com
WebSite www.altenergy.com

Your AES Distributor