



Pricelist December 2009

WB/POM LPG-Vaporizer /

Air Mixing Systems

Water Bath Vaporizer with POM Blending System

- Natural Gas Backup Systems
- Capacities from 14 MM BTU/h to over 400 MM BTU/h
- Complete with Vaporizer, Vapor/Air Mixer, Steel Skid, and Controls
- PLC Controls with Touch Screen Operator Interface for all systems
- Conforms to ASME, NFPA, NEC
- FM / IRI / CSA approved
- Vaporizers with 'Smart' Liquid Carryover Protection
- Available with PeakShaving Controller
- Small Footprint
- High Efficiency

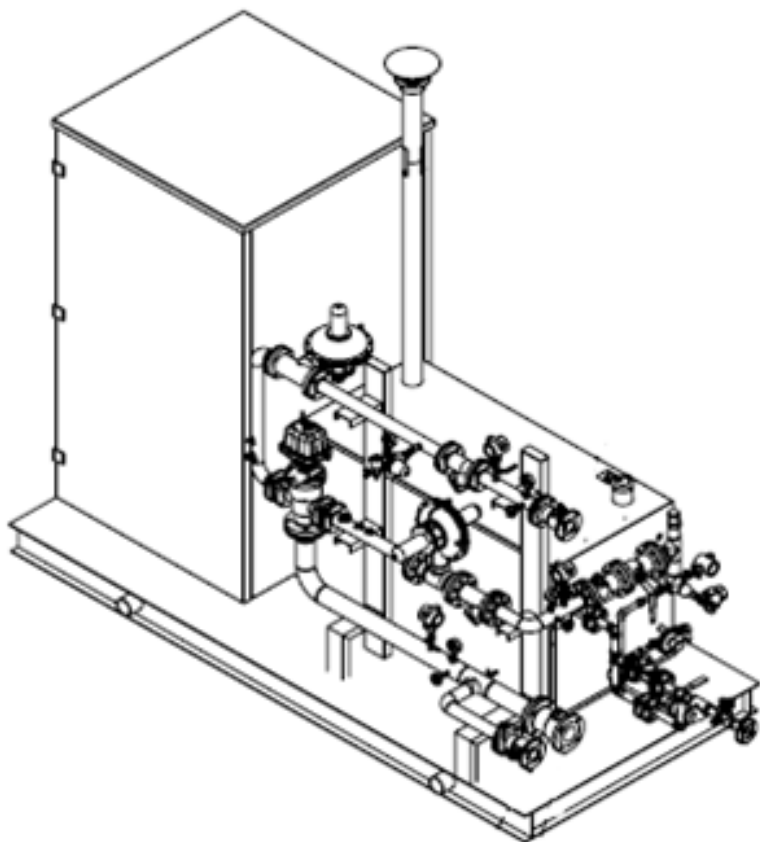

This price list supersedes the price list of July 2008 and all previous price lists. Prices shown in this list are believed to be accurate at the time of printing. They are given for standard equipment, standard options, and standard product configurations. All sales are subject to the terms and conditions as shown on page 16 of this price list. Please contact the factory or your nearest authorized AES distributor for a price quote and current delivery times. **Prices and product configurations are subject to change without notice.**

Options, Accessories for WB/POM Systems

The following list shows the most commonly requested options, accessories and spare parts for the WB/POM series of Water Bath Vaporizers and LPG/Air mixers. Unless listed otherwise, all options and accessories fit all vaporizer/blender models, except for models that have been modified for specific applications.

Part Number	Description	Price in US-\$
GB-3	Option: GraviBlend™-3, Gravimeter for LPG/Air mixtures, Standard Configuration for non-classified areas, Range 0.2 ... 2.2 (relative density). High-speed, high-accuracy, on-line gravimeter; measures and indicates specific gravity of mixed gas. Powder coated steel NEMA 4 wall-mount enclosure; integrated filter element in sample gas line; integrated consumption jet in sample gas line; integrated sample gas bypass with precision instrument valve; full-graphic color LCD display with touch screen operator interface (see Note 1); direct display of Specific Gravity, Calorific Value, and Wobbe Index number; electronic signal processor (see Note 1) with alarm contacts; internally powered analog output signal 4...20 mA (source; scaled to 0.4 ... 2.0 SG) for external recording instruments; AC110V 60Hz or AC220V 50Hz; graphic trend recording function; semi-automatic calibration feature.	\$16,934.00
GB-3E	Option: GraviBlend™-3E, Gravimeter for LPG/Air mixtures, Explosion-Proof Configuration for classified areas, Range 0.2 ... 2.2 (relative density). High-speed, high-accuracy, on-line gravimeter; measures and indicates specific gravity of mixed gas. Separate enclosures for electronic components, gas distribution elements, and density sensor. Electronics Enclosure (see Note 1): powder coated steel NEMA 4 wall-mount enclosure; full-graphic color LCD display with touch screen operator interface; direct display of Specific Gravity, Calorific Value, and Wobbe Index number; electronic signal processor (see Note 1) with alarm contacts; internally powered analog output signal 4...20 mA (source; scaled to 0.4 ... 2.0 SG) for external recording instruments; AC110V 60Hz or AC220V 50Hz; graphic trend recording function; semi-automatic calibration feature. Gas Distribution Enclosure: powder coated steel NEMA 4 wall-mount enclosure; integrated filter element in sample gas line; integrated consumption jet in sample gas line; integrated sample gas bypass with precision instrument valve; 1/8" bulkhead fittings for connection to Sensor Enclosure. Sensor Enclosure: explosion-proof aluminum junction box with density sensor and signal conditioner, wall-mount (horizontally).	\$21,914.00
WPOMACC	Option: AccuBlend™ System, Automatic Gas Properties Control. Electric actuator to adjust the angular position of the piston in the POM, and thereby correcting the calorific value of the mixed gas. Actuator is installed on top of the POM valve. Price includes proportional controller (integrated in electronic signal processor of GraviBlend™-3/3E; see Note 1), which receives a linear analog signal (4-20 mA or 0-5V) from the Gravimeter and sends a control signal to the actuator (requires "Option: Gravimeter").	\$8,855.00
WPOMETH	Siemens S7-1200 with 10-inch (640x480) Siemens Touch Panel with built-in Web Server for Remote Access and Control. System can be accessed with a standard web browser. No special software required.	\$3,834.00
WPOMFLOW	Flow Transmitter in sendout line; real-time SNG flow display on EOI. If the POM is equipped with a Gravimeter, LPG vapor flow, compressed air flow, and liquid LPG flow are also displayed. Dual Flow Totalizer (with individual reset) is standard for all displayed flow values.	\$7,909.00
WPOMTEM	Option: Three Temperature Transmitters; installed in vapor supply, air supply line, and mixed gas line. Each transmits a 4-20 mA signal to the PLC in the system control panel. Temperature display in engineering units, i.e. °F or °C. Includes Hi/Lo alarm setpoints for each transmitter; includes expansion analog input module for PLC.	\$3,862.00
WPOMMOD	Option: Module Unit. Installation of POM on same skid with water bath vaporizer. POM orientation is "vertical".	\$4,903.00
WPOMEX2	Option: Ex-proof control components; required for installations where the POM is more than 15 ft. away from a gas-fired vaporizer (U.S. rules), or where required by local law. Includes explosion-proof pressure transmitters in vapor supply line, air supply line, and mixed gas line. Interconnecting cable between explosion proof junction box at the blender skid and the vaporizer/blender control panel in the vaporizer control room is to be supplied and installed at job site. Maximum distance between blender and vaporizer approximately 2000 ft. (600 m). Includes local Start/Stop station, installed on blender skid.	\$6,076.00
WPOMCE-1	Option: CE Approval for vaporizer and blender; compliant with PED, ATEX, and all other applicable European Directives; WB-168/POM-10 to WB-408/POM-40	\$8,743.00
WPOMCE-2	Option: CE Approval for vaporizer and blender; compliant with PED, ATEX, and all other applicable European Directives; WB-458/POM-30 to WB-855/POM-40	\$9,679.00
WPOMCE-3	Option: CE Approval for vaporizer and blender; compliant with PED, ATEX, and all other applicable European Directives; WB-1005/POM-30 to WB-2205/POM-60	\$10,172.00
WPOMCE-4	Option: CE Approval for vaporizer and blender; compliant with PED, ATEX, and all other applicable European Directives; WB-2505/POM-40 to WB-5505/POM-60	\$12,066.00
POMPKSHV	Option: Electronic PeakShaving Controller. Includes PLC upgrades (10- or 12-inch color LCD display with Touch Screen Operator Interface; Analog Output for Flow Control Valve). Includes user-selectable PeakShaving modes (i.e. "Inject fixed SNG Volume"; "Limit NG Flow"; "Maintain NG/SNG Ratio"; ...). Includes electronically controlled Flow Control Valve in Mixed Gas Sendout Line (pneumatically actuated); Flow Transmitter in Mixed Gas Sendout Line; Analog Inputs for Grid Flow (or NatGas Flow), and Grid Pressure; block valve in Mixed Gas Sendout Line (pneumatically actuated).	Call Factory

Note 1: If the GraviBlend™-3/3E gravimeter is ordered together with a WB/POM system, the electronic signal processor of the gravimeter will be integrated into the PLC of the WB/POM system. The electronic operator interface will be a 7-inch high-resolution color LCD display with touch screen operator interface. An upgrade to a 10-inch Siemens MP277 or Allen-Bradley PanelView-Plus is available at a nominal charge of US-\$2,800.00.

Piston Operated Mixers (POM) with Water Bath Vaporizers

Model Numbers are WB-168/POM-10 to WB-3000/POM-60. The first part of the model number indicates the vaporizer capacity in gallons per hour, the second part indicates the mixer size (10 - 30 - 40 - 60). All systems combine horizontal water bath vaporizers (08-series or 05-series) with our patented Piston Operated Mixer (POM-series). They can be ordered for installation as individual units (water bath vaporizer and mixer within 15 ft [4.5m] of each other), or as a very compact "Module Unit" (see options), with the POM in "vertical" orientation and installed on the same skid with the vaporizer. In Module Units, all piping between the vaporizer and the blender, and all wiring between the blender and the control panel, are factory-installed, which can reduce installation time considerably. Both versions are equally reliable and have set the standard for value, reliability, ease-of-use, low maintenance, and high availability, in many different applications in many different countries, surpassing other high-capacity / high-pressure blender concepts by far.

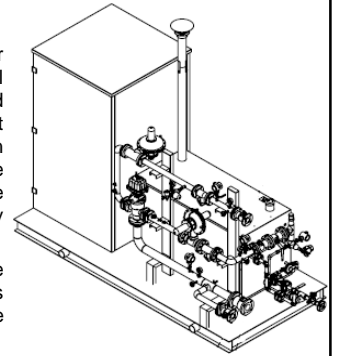

To select the correct vaporizer/blender combination, first determine the required vaporizer capacity by adding up the connected load. Including a safety factor of 1.1 to 1.3, select the vaporizer model. The capacity of the POM mixer depends on its configuration and the system pressure. In the table below, after selecting the vaporizer model, move to the right to the desired discharge pressure to find the POM model number and the price for the vaporizer/blender combination.

All WB/POM systems share the control panel between the WB vaporizer and the POM blender. The standard PLC is a Siemens S7-1200, or an Allen-Bradley MicroLogix-1100. Both PLCs have a built-in Ethernet Interface, and communicate with an Electronic Operator Interface (EOI) with high-resolution color LCD display and Touch Screen. Electrical connections between the POM blender and the control panel are made in two different ways:

In Module Units (POM blender on same skid with vaporizer), electrical connections run from the blender directly to the control panel. In individual units, all electrical connections are terminated in an explosion proof junction box at the POM skid. From there, a multi-wire cable (not included with system) is run to the mixer control panel in the vaporizer control room.

The WB/POM Series is designed for outdoor installation and requires only nominal preventive maintenance. Intended for intermittent or continuous service, the systems are manufactured to meet or exceed requirements of the ASME Pressure Vessel Code Section VIII, and the latest edition of NFPA Pamphlet #58. They are approved by Factory Mutual (FM) and Canadian Standards Association (CSA), and are suitable for Industrial Risk Insurers (IRI) installations. All systems are factory tested, primed, painted and ready for installation. They come with 2 sets of operating manuals and test reports.

All vaporizers in WB/POM systems are equipped with Rosemount Pressure and Temperature Transmitters in the Vapor Outlet of the vaporizer for "smart" Liquid Carryover Protection, based on pressure/temperature correlation and LPG type (Propane/Butane/...).

Nominal Capacity in BTU per hour and NatGas Equivalent** (m³/h; in bottom row) is strictly based on the vaporization capacity of the vaporizer, and is given for Propane/Air mixtures with 1450 BTU/cuft at delivered mixed gas pressures of 10 psig (0.7 bar) to 70 psig (5 bar). Capacity for other LPG/Air mixtures and/or pressures may vary. Nominal Capacity is based on vapor and compressed air inlet pressures of 100-125 psig, and a pressure drop of 10% across the mixing valve at maximum flow. The minimum vapor and air supply pressures are "Sendout Pressure + 15 psi (1bar)".

Other Vaporizer/Blender configurations (for lower or higher delivery pressures, higher flow rates, other blending gasses, different materials, ...) are available. Please contact the factory or your area distributor for details.

** NatGas Equivalent: In most cases, these systems will be used to provide backup for a NatGas supply. Including a sufficient safety factor (1.1 ... 1.3), use the maximum expected NatGas flow per hour to select the correct WB/POM model.

Vaporizer Model	Nominal Capacity**	System Discharge Pressure						
		10 psi	20 psi	30 psi	40 psi	50 psi	60 psi	70 psi
WB-168	15 MMBTU/h 424 m ³ /h	POM-30	POM-30	POM-10	POM-10	POM-10	POM-10	POM-10
		\$90,920.00	\$90,920.00	\$76,370.00	\$76,370.00	\$76,370.00	\$76,370.00	\$76,370.00
WB-208	19 MMBTU/h 538 m ³ /h	POM-30	POM-30	POM-10	POM-10	POM-10	POM-10	POM-10
		\$92,920.00	\$92,920.00	\$78,370.00	\$78,370.00	\$78,370.00	\$78,370.00	\$78,370.00
WB-258	24 MMBTU/h 679 m ³ /h	POM-30	POM-30	POM-10	POM-10	POM-10	POM-10	POM-10
		\$96,920.00	\$96,920.00	\$82,370.00	\$82,370.00	\$82,370.00	\$82,370.00	\$82,370.00
WB-308	28 MMBTU/h 792 m ³ /h	POM-30	POM-30	POM-30	POM-30	POM-30	POM-30	POM-30
		\$99,920.00	\$99,920.00	\$99,920.00	\$99,920.00	\$99,920.00	\$99,920.00	\$99,920.00
WB-358	33 MMBTU/h 934 m ³ /h	POM-30	POM-30	POM-30	POM-30	POM-30	POM-30	POM-30
		\$101,920.00	\$101,920.00	\$101,920.00	\$101,920.00	\$101,920.00	\$101,920.00	\$101,920.00
WB-408	37 MMBTU/h 1047 m ³ /h	POM-40	POM-30	POM-30	POM-30	POM-30	POM-30	POM-30
		\$111,256.00	\$103,420.00	\$103,420.00	\$103,420.00	\$103,420.00	\$103,420.00	\$103,420.00
WB-458	42 MMBTU/h 1189 m ³ /h	POM-40	POM-30	POM-30	POM-30	POM-30	POM-30	POM-30
		\$112,756.00	\$104,920.00	\$104,920.00	\$104,920.00	\$104,920.00	\$104,920.00	\$104,920.00
WB-508	47 MMBTU/h 1330 m ³ /h	POM-40	POM-30	POM-30	POM-30	POM-30	POM-30	POM-30
		\$115,756.00	\$107,920.00	\$107,920.00	\$107,920.00	\$107,920.00	\$107,920.00	\$107,920.00
WB-555	51 MMBTU/h 1444 m ³ /h	POM-40	POM-30	POM-30	POM-30	POM-30	POM-30	POM-30
		\$122,291.00	\$114,456.00	\$114,456.00	\$114,456.00	\$114,456.00	\$114,456.00	\$114,456.00
WB-655	60 MMBTU/h 1699 m ³ /h	POM-40	POM-30	POM-30	POM-30	POM-30	POM-30	POM-30
		\$126,082.00	\$118,245.00	\$118,245.00	\$118,245.00	\$118,245.00	\$118,245.00	\$118,245.00
WB-755	69 MMBTU/h 1953 m ³ /h	POM-40	POM-30	POM-30	POM-30	POM-30	POM-30	POM-30
		\$131,248.00	\$123,412.00	\$123,412.00	\$123,412.00	\$123,412.00	\$123,412.00	\$123,412.00
WB-855	79 MMBTU/h 2237 m ³ /h	POM-40	POM-40	POM-30	POM-30	POM-30	POM-30	POM-30
		\$134,341.00	\$134,341.00	\$126,504.00	\$126,504.00	\$126,504.00	\$126,504.00	\$126,504.00
WB-1005	92 MMBTU/h 2605 m ³ /h	POM-40	POM-40	POM-30	POM-30	POM-30	POM-30	POM-30
		\$142,777.00	\$142,777.00	\$134,941.00	\$134,941.00	\$134,941.00	\$134,941.00	\$134,941.00
WB-1205	111 MMBTU/h 3143 m ³ /h	POM-60	POM-40	POM-40	POM-30	POM-30	POM-30	POM-30
		\$165,613.00	\$148,398.00	\$148,398.00	\$140,563.00	\$140,563.00	\$140,563.00	\$140,563.00
WB-1505	139 MMBTU/h 3936 m ³ /h	POM-60	POM-40	POM-40	POM-40	POM-40	POM-30	POM-30
		\$174,099.00	\$156,885.00	\$156,885.00	\$156,885.00	\$156,885.00	\$159,643.00	\$159,643.00
WB-1805	166 MMBTU/h 4700 m ³ /h	Consult	POM-60	POM-40	POM-40	POM-40	POM-40	POM-30
			\$184,974.00	\$167,761.00	\$167,761.00	\$167,761.00	\$167,761.00	\$167,761.00
WB-2005	185 MMBTU/h 5238 m ³ /h	Consult	POM-60	POM-40	POM-40	POM-40	POM-40	POM-30
			\$199,082.00	\$181,867.00	\$181,867.00	\$181,867.00	\$181,867.00	\$181,867.00
WB-2205	203 MMBTU/h 5748 m ³ /h	Consult	POM-60	POM-40	POM-40	POM-40	POM-40	POM-40
			\$202,658.00	\$185,444.00	\$185,444.00	\$185,444.00	\$185,444.00	\$185,444.00
WB-2505	231 MMBTU/h 6541 m ³ /h	Consult	POM-60	POM-60	POM-40	POM-40	POM-40	POM-40
			\$229,242.00	\$229,242.00	\$212,028.00	\$212,028.00	\$212,028.00	\$212,028.00
WB-3005	277 MMBTU/h 7843 m ³ /h	Consult	POM-60	POM-60	POM-60	POM-40	POM-40	POM-40
			\$238,455.00	\$238,455.00	\$238,455.00	\$221,241.00	\$221,241.00	\$221,241.00

The table above shows WB/POM combinations for standard Propane. Configurations for other LPG mixtures may vary. Specifications are subject to change without notice. Call factory or distributor for price quotation and actual lead times.

Terms and Conditions, Warranty Information

The following are the standard terms and conditions of Alternate Energy Systems, Inc. for **domestic** customers. Actual terms and conditions for a specific order may have adjusted language and may be attached to the acknowledgement of the purchase order. Contact Alternate Energy Systems, Inc. for terms and conditions for export orders.

Acceptance:

Where these terms and conditions are incorporated in a proposal submitted by Alternate Energy Systems, Inc. ("Seller"), that proposal, together with these terms and conditions, expresses the Seller's entire undertaking and responsibility when the Purchaser's written order is transmitted to the Seller within thirty (30) days from the proposal date, and when the Purchaser's order is accepted by the Seller at its offices. Any previous quotations, agreements, conversations, or understandings, are superseded hereby.

For all other orders, these terms and conditions shall govern the contract between the Purchaser and the Seller. Any deviation from these terms and conditions must be agreed upon by the Seller, in writing. Specifically, the fact that Seller provides product in response to an order issued by the Purchaser, carrying deviating terms and conditions, does not automatically indicate that the Seller has accepted the Purchaser's terms and conditions.

Limited Warranty:

Seller guarantees that all products of its manufacture, sold pursuant hereto, shall be free of defects in workmanship and material, normal wear and tear excepted, for the standard period of one year from date of shipment from Seller. Certain products may carry shorter or longer warranty periods, in effect for these particular products at the time of shipment from the Seller. Commercial items, and other components, such as controls, electric motors, drives, etc., utilized in these manufactured products, are not guaranteed by Seller. Instead, they are covered by, and are subject to, their respective manufacturers' guarantees only. Complete products represented by, distributed by, or purchased and resold in any other manner by, Seller, are not guaranteed by Seller, but will be subject to their respective manufacturer's guarantee.

In the event of defects developing within the Seller's applicable guarantee period under normal and proper use, the Seller will only be obligated to furnish, F. O. B. point of manufacture or the Seller's plant, at its option, without charge, parts required to replace materials found defective; or, at Seller's option, replacement of defective item. Seller or its suppliers shall not be held liable for any further costs or expense, or for indirect or consequential damages, including removal or reinstallation cost, and lost profits. Deterioration or wear caused by chemicals, abrasive action, or excessive heat shall not constitute defects under warranty, unless such conditions are expressly provided for by the Seller, in writing. Products or parts that have been subject to accidental damage, misuse, unauthorized disassembly or alterations, improper installation, lack of proper lubrication, or lack of other service requirements established by the manufacturer, will not be covered by warranty. THE WARRANTY STATED HEREIN IS IN LIEU OF ALL OTHER WARRANTIES, EXPRESS, STATUTORY, OR IMPLIED; INCLUDING, WITHOUT LIMITATION, THAT OF MERCHANTABILITY AND FITNESS FOR A PARTICULAR PURPOSE.

Taxes:

Unless otherwise specifically noted in a proposal, prices quoted by seller do not include any applicable city, county, state or federal taxes. Any of these taxes to which a transaction is subject, are to be borne by the Purchaser, even if collection is required by the Seller.

Applicable Codes:

Seller or any manufacturer it represents, shall not be liable for any expense involved in meeting any federal, state or local codes. Federal codes, such as those represented in OSHA, refer to the employer (Purchaser) and not to the supplier (Seller). They cannot be delegated. However, the Seller will endeavor to help the Purchaser comply with these codes.

Component Equipment:

Seller's sales proposals are based on supplying its chosen make of motors, controls, drives and miscellaneous incidental equipment of the type required. If the Purchaser specifies a particular brand of one of these devices, the Seller reserves the right to charge any additional price involved, and its estimated shipping date is subject to such delays as may be required to obtain any non-stock item.

Shipping:

Seller will use all reasonable care in shipping the equipment and will endeavor to make shipment within the time estimated. However, it assumes no responsibility for loss of, or damage to, the equipment after shipment from its plant, or for unavoidable delays, such as those caused by fire, strikes, carriers, or other causes beyond the Seller's control. Unless instructed otherwise, all shipments will be insured at the buyer's expense and at the net invoice value of the goods.

Erection and Installation:

Seller assumes no responsibility for improper operation of equipment due to faulty erection or installation, when the equipment is erected by the Purchaser or his designates.

Cancellation:

All orders placed with, and accepted by, Seller are firm and not subject to cancellation, except by mutual consent. They are cancelable then only on terms that will indemnify the Seller against any losses incurred.

Claims:

Claims for shortages or damage to merchandise should be made to the transportation company making delivery. Should any piece of equipment prove defective, it will be repaired or replaced under the applicable warranty provided herein. Under no circumstances should any items be returned to Seller or the manufacturer from which Seller procured the item, without prior written Return Goods Authorization from Seller.

If Goods are returned without obtaining Return Goods Authorization, Seller and its associated manufacturers will not be responsible for the cost of repairs made in the field, if they are made without the written agreement of, and specific written instructions from, Seller and the affected manufacturer, if any.

Payment Terms:

Full net payment must reach Seller's office by the 30th day after invoice date. The following finance charges will apply for later payment, unless other agreements exist for that sale only:

The account is subject to a finance charge for late payment of the lower of (A) the maximum allowable rate, or (B) 1½ % per month (Annual Percentage Rate: 18%) on the total past due balance at any time that the past due balance includes any charge remaining unpaid 30 days after the date on which it was billed. There shall be no finance charge under a "Consumer Credit Transaction" as defined under the Federal Truth in Lending Law.

Governing Law:

This agreement has been executed in, and shall be governed by, the laws of the State of Georgia.

Security Agreement and Security Interest:

Purchaser agrees that Seller shall have and retain a security interest in the material furnished pursuant under this Agreement and, if full payment of all sums due is not received by Seller in accordance with the payment terms set forth herein and on the face hereof, Seller shall have the right to enter Purchaser's premises, and any other place where the material may be located, and repossess the material. This right of repossession shall be in addition to, and in no way in limitation of, any rights or remedies Seller may have under law or this Agreement by reason of Purchaser's failure to pay.

Purchaser's Acceptance of above Conditions:

All orders shall be subject to the terms and conditions described above, and to no others, whatsoever. When attached to the Seller's written quotation, this document contains the entire agreement between the parties, and there will be no oral or written understandings, terms or conditions, and Purchaser will not have relied upon any conditions or representation not contained therein. No waiver, alteration or modification of the terms and conditions on this and the other side hereof shall be binding unless in writing and signed by an executive officer or by a duly authorized representative of the Seller.

THE PURCHASER'S RECEIPT OF THE INVOICE SHALL CONSTITUTE AN ACCEPTANCE BY THE PURCHASER OF ALL THE TERMS AND CONDITIONS CONTAINED DESCRIBED ABOVE, AND ANY ATTACHMENT HEREOF OTHER THAN ANY TERMS OR CONDITIONS TO WHICH THE PURCHASER SHALL PROMPTLY TAKE EXCEPTION BY SPECIFIED WRITTEN OBJECTION.

Version 12/99 (05/04)